

2

Teknik Hizmetler ve Lojistik

Technical Services & Logistics

Genel	2-3	General	
Fuar Katılım Ücreti	2-3	Rental Fee	
Özel Stand Paketleri	2-4	Special Booth Packages	
Kiralanabilir ilave Stand Malzemeleri ve Donanımlar, Fuar Alanına Su ve Basıncılı Hava Temini	2-4	Additional Rental Furniture and Equipment, Water Supply, Compressed Air Supply	
Elektrik, Telefon, Faks ve İnternet Hizmetleri	2-5	Electricity, Phone, Fax and İnternet	
Kesintisiz Güç Kaynağı (UPS)	2-6	Uninterruptible Power Supply (UPS)	
Özel Güvenlik	2-6	Private Security	
Temizlik	2-6	Cleaning	
Fuar Hostesleri / Çevirmenler	2-6	Exhibition Hostesses / Translators	
Görsel Ekipman ve Sunu Sistemleri	2-6	Visual Equipment and Presentation Systems	
Nakliyat ve Lojistik Hizmetleri	2-7	Forwarding and Logistics Services	
Ek Hizmetler	2-8	Additional Services	
Önemli Tarihler- Servisler	2-9	Important Deadlines - Services	

TEKNİK HİZMETLER VE LOJİSTİK

İçindekiler

Teknik Hizmetler ve Lojistik	2-2
Genel	2-3
Fuar Katılım Ücreti	2-3
Özel Stand Paketleri	2-4
Kiralanabilir İlave Stand Malzemeleri ve Donanımlar, Fuar Alanına Su ve Basınçlı Hava Temini	2-4
Elektrik, Telefon, Faks, İnternet Hizmetleri	2-5
Kesintisiz Güç Kaynağı (KGK)	2-6
Özel Güvenlik	2-6
Temizlik	2-6
Fuar Hostesleri / Çevirmenler	2-6
Görsel Ekipman ve Sunu Sistemleri	2-6
Nakliyat ve Lojistik Hizmetleri	2-7
Ek Hizmetler	2-8
Önemli Tarihler- Servisler	2-9

TECHNICAL SERVICES & LOGISTICS

Content

Technical Services & Logistics	2-2
General	2-3
Rental Fee	2-3
Special Booth Packages	2-4
Additional Rental Furniture & Equipment, Water Supply, Compressed Air Supply	2-4
Electricity, Phone, Fax, Internet	2-5
Uninterruptible Power Supply (UPS)	2-6
Private Security	2-6
Cleaning	2-6
Exhibition Hostesses/ Translators	2-6
Visual Equipment and Presentation Systems	2-6
Forwarding & Logistics Services	2-7
Additional Services	2-8
Important Deadlines - Services	2-9

TEKNİK HİZMETLER VE LOJİSTİK

CeBIT Bilişim Eurasia'ya katılımınızın her yönüyle başarılı geçmesi için, sunduğumuz tüm hizmetlerle tarafınıza sağladığımız tüm olanaklar ile ilgili bilgiler ilerideki sayfalarda verilmiştir. Stand kurma, elektrik, telefon ve veri hatları, halı kaplama, ek stand malzemeleri ve görsel/işitsel sunum sistemleri bunlardan bir kaçıdır. Yapmanız gereken tek şey, ekteki hizmet istek formlarını doldurup belirtilen son teslim tarihinden önce HİF A.Ş.'ye göndermektir.

TECHNICAL SERVICES & LOGISTICS

The following pages contain information regarding all services we offer to make your participation at CeBIT Bilişim Eurasia an all round success. We provide all the necessary facilities including booth construction, electricity, telephone and data lines, carpeting, additional booth materials and audiovisual presentation systems. All you need to do is complete the attached service request forms and return them to HIF A.Ş. before the stated deadlines.

Genel

Katılımcı şirketler tarafından talep edilen teknik hizmetlerin firma standartlarına doğru biçimde ulaştırılmasını ve stand yapımına uygun olmasını sağlamak üzere, katılımcı şirketlerin mimarlarından destek almaları önerilir.

HİF A.Ş. tarafından sağlanacak bir hizmet için, belirtilen son başvuru tarihinden sonra bir talep geldiğinde, HİF A.Ş. bu hizmetin sağlanmasını garanti etmez. Bu tarihten sonra alınan talepler için liste fiyatı %50 artırılır.

Eksik, gecikmiş ve gönderilmemiş formlardan kaynaklanan sorunlardan HİF A.Ş. sorumlu değildir.

Fuar Katılım Ücreti

Fuara katılım, "metre kare başına" esasına göre ücretlendirilir. Metre kare başına ücret, stand olmaksızın, yalnızca kiralanan zemin alanını kapsar.

Zemin alanı kira ücreti 290 YTL/m² + %18 KDV'dir. Bu fiyat tüm fuar süresi için geçerlidir.

Bu ücrete dahil olan hizmetler:

- Standların m²'leri ve yerlerinin belirlenmesi.
- Fuarın tanıtılması ve duyurusu, danışma ve teknik servis bürolarının kullanımı, fuar genel güvenliğinin sağlanması.
- Genel temizlik hizmetlerinin sağlanması (stand içi temizliği müşteriye aittir)
- Afişlerin, fuar kataloğunun ve tanıtım broşürlerinin basımı ve dağıtımı dahildir.

Üst kat kullanım fiyatı 15 YTL/m²+KDV'dir. Söz konusu olabilecek diğer hizmetlerin bedelleri hizmet ile ilgili formlarda bulunmaktadır.

General

Exhibitors are advised to obtain support from their architects in order to ensure that the technical services which they requested reach their booths in the correct manner and suit the construction of the booth.

If a request for a service to be provided by HİF A.Ş. is received after the specified deadline, HİF A.Ş. does not guarantee to supply these. The listed price will be increased by 50% for requests received after this date.

HİF A.Ş. is not responsible for problems arising from incomplete, late or unsubmitted forms.

Rental Fee

Participation in the show is charged on a "per square meter (sqm)" basis. The charge per sqm covers only the actual floor space rented, without any booth.

The charge for floor space is EUR 180 per sqm +18%VAT. This price is valid throughout the fair.

This charge includes:

- The sqm areas of stands and their localization
- Promotion and advertisements, consultancy and utilization of technical service offices, and providing the general security of the exhibition area,
- Providing general cleaning services (in-stand cleaning shall be provided by the Customer)
- Printing and distributing the posters, show catalogue and leaflets.

Fees for any additional services are quoted on the relevant forms.

Özel Stand Paketleri

Standınızın tasarımı ve montajı konusunda zaman ve paradan tasarruf etmek isterseniz, aşağıdaki alternatiflerden birini seçebilirsiniz:

Paket 2: 340 YTL /m² + %18 KDV

Bu fiyata Boş alan kiralama, Stand yapımı,alın yazısının yazılması, Halı, Kurulan stand metrekaresinden bağımsız olmak üzere 3 kW elektrik kullanımını sağlayan 3'lü priz, 3m²'ye 100 Watt'lık spot ve spotların yanması için gereken elektrik enerjisi (3kW, 220V, 50 Hz) dahildir.

Paket 3: 400 YTL /m² + %18 KDV

Paket 2'ye ilave olarak, kurulan stand metrekaresinden bağımsız olmak üzere; 1 verzalit yuvarlak masa, 3 adet verzalit sandalye, 1mx1m olmak üzere kapısı olan depo, Danışma masası sağlanacaktır.

Özel Stand Paketi Kiralama:

İstek Formu **2a**

Son Başvuru Tarihi **28.08.2007**

Standların dekorasyonu ile ilgili tüm masraflar katılımcı şirketler tarafından yüklenilir.

Kiralanabilir İlave Stand Malzemeleri ve Donanımlar, Fuar Alanına Su ve Basınçlı Hava Temini

İster masa, sandalye, lamba ya da halı, ister buzdolabına ihtiyaç duyuyor olun, standınızı tam istediğiniz gibi yapmanız için HİF A.Ş. size her şeyi sağlar.

Kiralanabilir İlave Stand Malzemeleri ve Donanımlar, Stand alanına Su ve Basınçlı Hava Temini:

İstek Formu **2b**

Son Başvuru Tarihi **28.08.2007**

Special Booth Packages

If you'd like to save time and money designing and putting together your booth, you can choose one of the following configurations:

Package 2: EUR 205 per/sqm + 18 % VAT

This price includes Floor space, Aluminum frame construction, White wall panels, Fascia panel with booth number and company name, Spotlights (100 W per 3 sqm), 3 kW of electricity, 3 power sockets (220V, 50Hz) (all regardless of the actual rented area)

Package 3: EUR 235 per/sqm + 18 % VAT

Same as option 2, plus 1 Table, 3 chairs, 1mx1m lockable storage space, information desk (all regardless of the actual rented area)

Special Booth Package:

Request Form **2a**

Deadline **28.08.2007**

All expenses related to the decoration of the booths themselves are to be borne by the exhibitors.

Additional Rental Furniture & Equipment, Water Supply, Compressed Air Supply

Whether you need tables, chairs, lamps, carpeting or a refrigerator, HİF A.Ş. can provide everything to make your booth exactly as you wish.

Additional Rental Furniture & Equipment, Water Supply, Compressed Air Supply::

Request Form **2b**

Deadline **28.08.2007**

Elektrik, Telefon, Faks ve İnternet Hizmetleri

Müşterilerinizin ve diğer ilgili şahısların fuar süresince size telefon, faks ve ePosta ile ulaşabilmeleri için tüm bağlantılarınızın yapılmış olduğundan emin olunuz. Yapmanız gereken tek şey, aşağıdaki istek formunu doldurmak ve imzalayarak formda belirtilen faks numarasına göndermektir:

Elektrik, Telefon, Faks ve İnternet Hizmetleri:
İstek Formu 2c

Son Başvuru Tarihi **28.08.2007**

Standınızı kurmaya başlamadan önce, gerekli altyapısal unsurların (su, elektrik, veri ve telefon kabloları) kanaldan stand alanınıza sağlanmış olduğunu kontrol edin.

Telefon hattının uluslararası aramalara açık ya da kapalı olması gerektiğini İstek Formu 2c üzerinde belirtmeyi unutmayınız. Kendi alanlarına telefon hattı talep edenlere yalnızca hat hizmeti verilir ve ilgili altyapı kurulur. Hattın sonunda bir konektör mevcuttur. Hattı kullanmak için katılımcı şirketlerin kendi telefonlarını getirmeleri gereklidir.

Katılımcı şirketler veri hattı talep ettiğinde, HİF A.Ş. Türk Telekom'a başvuruda bulunarak başvuru sürecini izler ve hattın standda kurulmasını ve kontrol edilmesini sağlar. Veri hattını standda kullanabilmek için katılımcı şirketlerin uygun modemi sağlamaları gereklidir.

Fuar sırasında kaç kW güce gereksiniminiz olacağını Elektrik, Telefon, Faks ve İnternet formunun ilgili bölümünde belirtiniz. Her kW elektrik için maliyet 45 YTL + KDV'dir. Bu fiyata, elektrik kablolarının standınıza çekilmesi ve kullandığınız elektriğin ücreti dahildir.

Electricity, Phone, Fax and Internet

Make sure you are fully connected so that your customers and other interested parties can reach you at the show by phone, fax and e-mail. All you need to do is to fill out the following request form, sign it and fax it to the number indicated on the form:

Electricity, Telephone, Fax and Internet:
Request Form 2c
Deadline **28.08.2007**

Please check that the required infrastructural elements (water, electricity, data and telephone lines) have been provided from the channels to your booth area before you commence construction of your booth.

Please do not forget to indicate on the Request Form 2c if the telephone line should be open or closed to international calls. For those who request a telephone line to their area, only the line service will be given and the related infrastructure will be installed. A connector will be found at the end of the line. Exhibitors are asked to remember that they must bring their own telephones in order to use the line.

When exhibitors request data lines, HİF A.Ş. submits an application to Turkish Telekom, monitors the progress of the application and ensures that the line is installed at the booth and checked. Exhibitors must supply the necessary modem in order to use the data line at the booth.

Please indicate how many kilowatts of power that you will require during the show in the given section of the Electricity, Telephone, Fax and Internet form. The cost for each kW of electricity is EUR 22 + VAT. This price includes the provision of electricity cables to your booth and the cost of the electricity you use.

Kesintisiz Güç Kaynağı (KGK)

Fuar alanında ortaya çıkabilecek elektrik kesintilerinden, düşük voltaj ve uyumsuz ağ elektrik kaynakları ve cihazlarından kaynaklanan sorunları ortadan kaldırmak amacıyla, KGK kullanmanızı öneririz.

Kesintisiz Güç Kaynağı KGK
İstek Formu **2d**
Son Başvuru Tarihi **04.09.2007**

Elektrik kesintileri, düşük voltaj ve uyumsuz ağ elektrik kaynağı ile cihazlarından kaynaklanabilecek sorunlar HİF A.Ş.'nin sorumluluğunda değildir.

Özel Güvenlik

HİF A.Ş., fuar alanı bütününde genel bir güvenlik hizmeti verir. Ancak, fuar süresince standınızı gözetim altında tutacak düzenlemeleri yapmanızı öneririz.

Özel Güvenlik: İstek Formu **2e**
Son Başvuru Tarihi **04.09.2007**

Temizlik

HİF A.Ş., genel temizlik ve koridor temizliğinden sorumludur. Standların temizliği stand sahiplerine aittir. Standınızın günlük temizliği için kendi personelinizi kullanmak istemezseniz, HİF A.Ş.'tan profesyonel temizlik elemanları kiralayabilirsiniz (yalnızca zemin temizliği yapılır, elektrikli süpürge ya da uzun saplı temizlik fırçaları kullanılır). Aşağıdaki formu doldurarak bu hizmet için talepte bulunabilirsiniz:

Temizlik : İstek Formu **2f**
Son Başvuru Tarihi **04.09.2007**

Fuar Hostesleri / Çevirmenler

Konuklarınızla ilgilenmek ve onların ihtiyaçlarını karşılamak üzere size yardımcı olacak deneyimli, iki dil bilen hostesler fuar alanında olacaktır. İyi bir iletişim için çeşitli dil becerilerine sahip nitelikli çevirmenleri öneririz.

Fuar Hostesleri/ Çevirmenler: İstek Formu **2g**
Son Başvuru Tarihi **04.09.2007**

Görsel Ekipman ve Sunu Sistemleri

CeBIT Bilişim Eurasia tarafından sunulan görsel sunum sistemleri, tüm işitsel/görsel ihtiyaçlarınızı en yüksek standartlarda karşılar. Lütfen, aşağıdaki istek formunu doldurunuz:

Görsel Ekipman ve Sunu Sistemleri:
İstek Formu **2h/ 2i**
Son Başvuru Tarihi **14.08.2007**

Uninterruptible Power Supply (UPS)

In order to eliminate problems caused by electricity cuts which may occur on the premises, low voltage or incompatibility of network electricity and appliances, we recommend using a UPS.

Uninterruptible Power Supply UPS:
Request Form **2d**
Deadline **04.09.2007**

HİF A.Ş. may not be held responsible for any problems caused by electricity cuts, low voltage or incompatibility of network electricity and appliances.

Private Security

HİF A.Ş. operates a general security service throughout the exhibition grounds. However, we recommend that you make arrangements to have your booth kept under surveillance during the entire exhibition

Private Security: Request Form **2e**
Deadline **04.09.2007**

Cleaning

HİF A.Ş. is responsible for general cleaning and cleaning of the corridor. Cleaning of the booths is the responsibility of the booth owner. If you prefer not to use your own staff for the daily task of booth cleaning, you can hire professional cleaners from HİF A.Ş. (only floors will be cleaned, either with a vacuum cleaner or a mop if suitable). In order to request this service, please fill in the following form

Cleaning : Request Form **2f**
Deadline **04.09.2007**

Exhibition Hostesses/ Translators

Friendly and experienced bilingual hostesses are at hand to assist you in looking after your guests and attending to their needs. For optimal communication we recommend qualified translators with a wide range of language skills.

Exhibition Hostesses/ Translators: Request Form **2g**
Deadline **04.09.2007**

Visual Equipment & Presentation Systems

The visual presentation systems offered for CeBIT Bilişim Eurasia will satisfy all your audiovisual needs to the highest standards. Please fill in the following request form:

Visual Equipment & Presentation Systems:
Request Form **2h / 2i**
Deadline **14.08.2007**

Nakliyat ve Lojistik Hizmetleri

Resmi Lojistik Şirketi size şu hizmetleri sunar: Gümrükten mal çekme, ürünlerinizin doğrudan standınıza nakliyesi ve paketlenen malzemelerin depolanması. Fuardan sonra, yeniden paketleme işini üstlenecek ve ürünlerinizi gümrüğe teslim edeceklerdir.

- o Gümrük
- o Nakliyat
- o Lojistik Hizmetleri

EKOL LOJİSTİK A.Ş.

*Gülbahar Caddesi Gürol Sokak No:1 Evren Mah.
Güneşli 34212 İstanbul / TÜRKİYE
Telefon : +90 (212) 651 86 00
Faks : +90 (212) 651 86 13
İlgili Kişi : Ersin Zafer
ePosta : ersin.zafer@ekol.com*

Son Başvuru Tarihi **04.09.2007**

Forwarding & Logistics Services

The Official Logistics Company has been appointed to provide you the following services: Customs clearance, transport of your products directly to your booth and storing of the packaging materials. After the show they will take care of the repackaging and deliver your products to Customs.

- o Customs
- o Transport
- o Logistics Services

EKOL LOGISTIC A.Ş.

*Gülbahar Caddesi Gürol Sokak No:1 Evren Mah.
Güneşli 34212 İstanbul / TURKEY
Phone : +90 (212) 651 86 00
Fax : +90 (212) 651 86 13
Contact Name : Ersin Zafer
eMail : ersin.zafer@ekol.com*

Deadline **04.09.2007**

Ek hizmetler

- o İş gücü tedariki.
- o 3–5 ton kapasiteli forklift.
- o 10–30 ton kapasiteli vinç.
- o Paketleme ve paket açma.

1. Sergilenecek ürünlerin gümrük antreposundan standı nakliyesi.

a) Havaalanından fuar alanına ücretsiz nakliye, gelen kamyonlardan yüklerin boşaltılması ve sergilenecek ürünlerin gerekli ekipmanlar (forklift, vinç vb.) ve personelle birlikte katılımcı şirket standına nakliyesi.

b) Limandan (deniz yolu nakliyesi için) fuar alanına ücretsiz nakliye, gelen kamyonlardan yüklerin boşaltılması ve sergilenecek ürünlerin gerekli ekipmanlar (forklift, vinç) ve personelle birlikte katılımcı şirket standına nakliyesi.

c) Nakliyatçı şirketin anlaşmalı olduğu gümrük antreposundan (karayolu nakliyesi için) fuar alanına ücretsiz nakliye, gelen kamyonlardan yüklerin boşaltılması ve sergilenecek ürünlerin gerekli ekipmanlar (örneğin, forklift, vinç) ve personelle birlikte katılımcı şirket standına nakliyesi.

2. Gümrükten mal çekme

ATA KARNESİ ile gümrükten mal çekme. Ata Karnesi çevirisi ya da fatura. Ticari Fatura ile geçici süreli gümrükten mal çekme. Sürekli gümrükten mal çekme.

3. Boşalan ambalaj kutularının saklanması

Boşalan ambalaj kutularını standdan toplama, depolama alanına götürme, yağmur koruyucu ile depolama, depolama alanı kiralama ve fuar sonunda boş ambalaj kutularını standı geri getirme bu işlemlerden birkaçıdır.

Additional services

- o Supply of labor.
- o 3-5 ton capacity forklift.
- o 10-30 ton capacity crane.
- o Packing and un-packing.

1. Delivery of exhibits from bonded warehouse to booth

a) Collection from the airport with free transport to the showgrounds, unloading of inbound trucks and delivery of exhibits to the exhibitor's booth including the necessary equipment (e.g. forklift, cranes) and personnel.

b) Collection from the harbor (of sea freight) with free transport to the showgrounds, unloading of inbound trucks and delivery of exhibits to the exhibitor's booth including the necessary equipment (e.g. forklift, cranes) and personnel

c) Collection from Forwarder bonded warehouse (truck freight) to free arrival to the showgrounds unloading of inbound trucks and delivery of exhibits to the exhibitor's booth including the necessary equipment (e.g. forklift, cranes) and personnel.

2. Customs clearance

CARNET ATA clearance. Translation of Carnet ATA or invoice. Temporary Customs clearance with Commercial Invoice. Permanent Customs clearance.

3. Handling of empties

Includes collecting empties from the booth, transport to storage area, storage with rain cover, rental of storage area and returning empties to the booth upon close of the exhibition.

	Form #	Son Tarih / Deadline	Check	
Özel Stand Paketi	2a	28.08.2007	<input type="checkbox"/>	Special Booth Package
İlave Stand Malzemeleri ve Donanımlar, Fuar Alanına Su ve Basıncı Hava Temini	2b	28.08.2007	<input type="checkbox"/>	Additional Rental Furniture& Equipment, Water Supply, Compressed Air Supply
Elektrik, Telefon, Faks ve İnternet Hizmetleri	2c	28.08.2007	<input type="checkbox"/>	Electricity, Telephone, Fax and Internet
Kesintisiz Güç Kaynağı (KGK)	2d	04.09.2007	<input type="checkbox"/>	Uninterruptible Power Supply (UPS)
Özel Güvenlik	2e	04.09.2007	<input type="checkbox"/>	Private Security
Temizlik	2f	04.09.2007	<input type="checkbox"/>	Cleaning
Fuar Hostesleri/ Çevirmenler	2g	04.09.2007	<input type="checkbox"/>	Exhibition Hostesses/ Translators
Görsel Ekipman ve Sunu Sistemleri Kiralama - I	2h	14.08.2007	<input type="checkbox"/>	Visual Equipment & Presentation Systems Rental - I
Görsel Ekipman ve Sunu Sistemleri Kiralama - II	2i	14.08.2007	<input type="checkbox"/>	Visual Equipment & Presentation Systems Rental - II

Formlar, konularıyla ilgili seperatörlerin açıklama/ bilgi sayfalarının sonunda bulunmaktadır. Form numaralarındaki rakam seperatörleri ifade etmektedir.

Forms are located after the information pages under the separator for each subject. The number in the form name indicates the separator number.

Special Booth Package

Hall No.

Booth No.

Exhibitor Phone No
 Address GSM No
 City / Country Fax No
 Authorized Person E-mail



OPTION 2



Euro 25 per m² + 18 % VAT

- Aluminum frame construction
- White wall panels
- Fascia panel with both number and company name
- Spotlights (100 W per 3 m²)
- 3 power sockets (220 V, 50 Hz)



OPTION 3

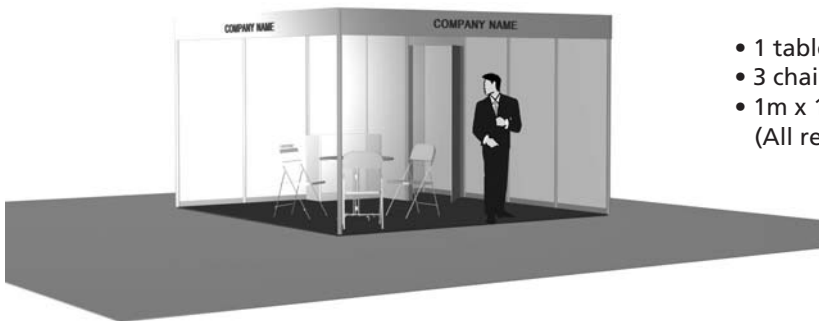

Euro 55 per m² + 18 % VAT

Same as Option 1, plus;

- 1 table
- 3 chairs
- 1m x 1m lockable storage space
(All regardless of the actual rented area)

Submission Deadline **28.08.2007**

Fax No.

+90 (212) 334 69 70

E-mail

teknik@hifas.com

**Additional Rental Furniture & Equipment,
Water supply, Compressed Air Supply**

Hall No.

Booth No.

Exhibitor

Address

City / Country











Authorized Person









Phone No

GSM No

Fax No

E-mail

CODE NO	TYPE	PIECES	€/PIECE	TOTAL
221	DIVIDING PANEL H: 234 W: 95.5 		30 €	
231	DOOR (WITH A LOCK) H: 208 cm W: 83 cm 		112 €	
222	HALF DIVIDING PANEL H: 234 cm W: 47.8 cm 		18 €	
105	TABLE H: 75cm W: 75cm I: 120cm 		41 €	
210	TABLE H: 75cm W: 60cm I: 110cm 		35 €	
000	CARPET RIP Standart to, Blue, Red, Green, Beige, Grey 		9 €/m ²	
216	LOCKER H: 90cm W: 37cm I: 102cm 		65 €	
224	SHELF A: 30 cm B: 100 cm 		18 €	
209	INFORMATION DESK H: 102cm W: 52cm I: 102cm 		47 €	
201	ILLUMINATED SHOWCASE H: 102 cm W: 52 cm I: 102 cm 		50 €	
205	DISPLAY CABINET H: 200 cm W: 52 cm I: 52 cm 		70 €	
1. COLUMN TOTAL				

CODE NO	TYPE	PIECES	€/PIECE	TOTAL
309	LEATHER CHAIR H: 80cm 		32 €	
301	CHAIR H: 70cm 		24 €	
307	BAR STOOL H: 75cm 		30 €	
411	REFRIGERATOR H: 82cm W: 56cm I: 60cm 		97 €	
318	WASTEBASKET H: 50cm 		10 €	
416	SPOT LIGHT (100 Watt) 		16 €	
415	HALOGEN SPOT LIGHT 300 W 		30 €	
418	EXTENSION CORD 		12 €	
020	WATER CONNECTION AND WATER SUPPLY		82 €	
021	COMPRESSED AIR (7 BAR) CONNECTION AND AIR SUPPLY		82 €	
2. COLUMN TOTAL				

GENERAL TOTAL €

1 + 2

- Fees for extra booth equipment or services ordered, for CeBIT Bilişim Eurasia have to be paid during the fair in cash.
- VAT is not included in the prices
- The above mentioned prices are valid for requests send to HİF A.Ş. until 28 August, 2007.
- Any orders that reach HİF A.Ş. after 28 August, 2007 and orders given at the Fair shall be charged for at arate 50 % higher than the indicated price.
- Our stocks are limited.

CeBIT
eurasia
Bilişim

ISTANBUL
2-7.10.2007

Date

Stamp / Authorized Signature

Submission Deadline **28.08.2007**

Fax No.
E-mail

+90 (212) 334 69 70
teknik@hifas.com

FORM NO.

2c

Electricity, Telephone, Fax and Internet

Hall No.

Booth No.

Exhibitor Phone No
Address GSM No
City / Country Fax No
Authorized Person E-mail

Electricity Power kW : kW (22 € / kW)

ADSL : 512 Kbps 300€ 1 Mbps 500€ 2 Mbps 700€

Telephone Line : 145€ (No telephone or fax machine)

Leased Line : 512 Kbps 700€ 1 Mbps 900€ 2 Mbps 1200€

L. 1st Line Termination

Address :
City :
Telephone : Contact person

L. 2nd Line Termination

Will be brought to your stand at the fair

NOTE: The devices to be attached to each end of the line (modem etc) are not included in the service.

- The internet line will be provided using telephone cable CAT5. Distribution within the stand (**for example Hub, Router and Switch**) is the responsibility of exhibitors. ADSL Modem and Leased line Modem will be in exhibitors responsibility.
- Exhibitors who wish to receive wireless internet service can do so by providing the ID number of their wireless cards to HİF A.Ş. representatives.
- A box will be connected to the end of the telephone cable. The connector will be attached by the customer.
- The Euro 145 charge for the telephone line is a charge for the line and its installment. **No telephones or fax machines will be provided.**
- Electricity cables supplied to stands by HİF A.Ş. will terminate in a triple group socket.
- Where companies are constructing their own stands, the distribution of the electricity cable within the stand is the responsibility of exhibitors. For companies who so request, tri-phase cable with an open termination can be provided. (Euro 22/kWh)
- Please include all electric equipment and lighting when calculating your electricity needs.
- For special requests, please contact teknik@hifas.com directly.
- VAT is not included in prices. Services will be invoiced for in October 2007.

ATTENTION!

Must be filled in by all exhibitors.

CeBIT
eurasia
Bilişim
ISTANBUL
2-7.10.2007

.....
.....

Date

Stamp / Authorized Signature

Uninterruptible Power Supply (UPS)

Hall No.

Booth No.

Exhibitor Phone No
 Address GSM No
 City / Country Fax No
 Authorized Person E-mail

Please choose an Uninterruptible Power Supply (UPS) type for your booth, equipment and devices.

<p>3kVA - 20kVA</p> <p>Unit Price € 80 /kVA</p> <p>Your needkVA</p>	}	<p><input type="checkbox"/> 3kVA € 230</p> <p><input type="checkbox"/> 5kVA € 380</p> <p><input type="checkbox"/> 10kVA € 760</p> <p><input type="checkbox"/> 15kVA € 1150</p> <p><input type="checkbox"/> 20kVA € 1500</p>
<p>30kVA - 45kVA</p> <p>Unit Price € 70 /kVA</p> <p>Your needkVA</p>	}	<p><input type="checkbox"/> 30kVA € 1900</p> <p><input type="checkbox"/> 45kVA € 2800</p>
<p>60kVA - 200kVA</p> <p>Unit Price € 60 /kVA</p> <p>Your needkVA</p>	}	<p><input type="checkbox"/> 60kVA € 3200</p> <p><input type="checkbox"/> 80kVA € 4300</p> <p><input type="checkbox"/> 100kVA € 5400</p> <p><input type="checkbox"/> 120kVA € 6500</p> <p><input type="checkbox"/> 160kVA € 8600</p> <p><input type="checkbox"/> 200kVA € 11.000</p>

- VAT is not included in prices.
- Assembling is included in prices.
- Delivery shall be two days before the fair.
- UPS fees shall be invoiced in October 2007.



.....

Date

Stamp / Authorized Signature

www.cebitbilisim.com

Submission Deadline **04.09.2007**

Fax No.
E-mail

+90 (212) 334 69 70
teknik@hifas.com

FORM NO.

2e

Private Security

Hall No.

Booth No.

Exhibitor Phone No
 Address GSM No
 City / Country Fax No
 Authorized Person E-mail

• SECURITY

Please check the dates you need for security service.

25 Tuesday	26 Wednesday	27 Thursday	28 Friday	29 Saturday	30 Sunday	September 2007	1 Monday	October 2007
2 Tuesday	3 Wednesday	4 Thursday	5 Friday	6 Saturday	7 Sunday	October 2007		

()
OK

Security Staff Persons
 From
 To
 Total Day(s)

12 Hours 90 Euro+ 18%VAT

- Please contact teknik@hifas.com for security service prices.
- VAT is not included in prices
- Service will be invoiced in October 2007.

ATTENTION!

- Fees for extra booth equipment or services ordered for CeBIT Bilişim Eurasia have to be paid during the fair by cash.



.....

Date

Stamp / Authorized Signature



www.cebitbilisim.com

Submission Deadline **04.09.2007**

Fax No.

+90 (212) 334 69 70

E-mail

teknik@hifas.com

Cleaning

Hall No.

Booth No.

Exhibitor Phone No
 Address GSM No
 City / Country Fax No
 Authorized Person E-mail

• CLEANING

Please check the dates you need for Cleaning service.

Preparation Period Prior to Fair

29 Saturday	30 Sunday	September 2007	1 Monday	October 2007
----------------	--------------	-------------------	-------------	-----------------

()
OK

During the Fair

2 Tuesday	3 Wednesday	4 Thursday	5 Friday	6 Saturday	7 Sunday	October 2007
--------------	----------------	---------------	-------------	---------------	-------------	-----------------

Cleaning Staff Persons

From

To

Total Day(s)

Booth Space Square meters (if exists, please include the second floor)

Per day 2 Euro/sqm

- Private cleaning services shall be provided only if requested.
- Please contact teknik@hifas.com for cleaning service prices.
- VAT is not included in prices
- Service will be invoiced in October 2007.

ATTENTION!

- Fees for extra booth equipment or services ordered for CeBIT Bilişim Eurasia have to be paid during the fair in cash.



.....

Date

Stamp / Authorized Signature



Exhibition Hostess/ Translators

Hall No.

Booth No.

Exhibitor Phone No
 Address GSM No
 City / Country Fax No
 Authorized Person E-mail

Only verbal translations and reading services may be requested from the translators. No written translations are permitted. Hostesses can communicate in English and Turkish.

TRANSLATOR

Language*	Number of Translators	W o r k i n g P e r i o d		Total Price
		From	To	
English <input type="checkbox"/>
German <input type="checkbox"/>
French <input type="checkbox"/>
Japanese <input type="checkbox"/>
Italian <input type="checkbox"/>
Russian <input type="checkbox"/>
Chinese <input type="checkbox"/>

HOSTESS

Number of Hostess	Duration of employment	Total Price
.....

- Covers translation services from preferred language into Turkish and vice versa. Please inform our service representatives of all your translation needs.
- Hostess fees: 70 Euro + VAT/ Day. (8 Hours) Translator fees: _____ Euro + VAT/ Day.
- Translator and hostess service fees shall be invoiced in October 2007.
- VAT is not included in the prices.

ATTENTION!

- Fees for extra booth equipment or services ordered for CeBIT Bilişim Eurasia have to be paid during the fair in cash.



Date

Stamp / Authorized Signature

Submission Deadline **14.09.2007**

Fax No.

+90 (212) 334 69 70

E-mail

teknik@hifas.com

FORM NO.

2h

Visual Equipment & Presentation Systems Rental - I

Hall No.

Booth No.

Exhibitor Phone No
 Address GSM No
 City / Country Fax No
 Authorized Person E-mail

VIDEO / DATA PROJECTORS

Product	Order Qty.	Unit Price	€ Total
2.500 ANSI / 2000 Contrast		€ 420	
4.500 ANSI / 2000 Contrast		€ 1100	

PROJECTION SCREENS

Product	Order Qty.	Unit Price	€ Total
150 x 200 cm		€ 420	
200 x 300 cm		€ 510	
300 x 400 cm		€ 630	

LED SYSTEMS

Product	Order Qty.	Unit Price	€ Total
M2		€ 1500	

SOUND SYSTEMS

Product	Order Qty.	Unit Price	€ Total
2 Speaker, Amphi, Mixer, 1 un. Wireless Mic-1un. Head Set CD Player		€ 1.200	
4 Speaker, Amphi, Mixer, 1 un. Hand Wireless Mic-1un. Head Set CD Player		€ 1.520	
8 Speaker, Amphi, Mixer, 1 un. Hand Wireless Mic-1un. Head Set CD Player		€ 1.900	
Home Theater		€ 950	
Hi-Fi Ses Stereo 2 Speaker, CD Player, Radio		€ 700	

PLASMA DISPLAYS

Product	Order Qty.	Unit Price	€ Total
50 Inch. 127 cm 1024 x 768		€ 750	
42 Inch. 106 cm 1024 x 768		€ 420	

VIDEO EQUIPMENT

Product	Order Qty.	Unit Price	€ Total
Betacam Player		€ 680	
DVD Player		€ 110	

GENERAL TOTAL	€
---------------	---

- Fees for extra booth equipment or services ordered, for CeBIT Bilişim Eurasia have to be paid during the fair in cash.
- VAT is not included in the prices
- The above mentioned prices are valid for requests send to HIF A.Ş. until 14th August, 2007.
- Any orders that reach HIF A.S. after 14th August, 2007 and orders given at the Fair shall be charged for at arate 50 % higher than the indicated price.
- Our stocks are limited.



Date

Stamp / Authorized Signature

Submission Deadline **14.09.2007**

Fax No.

+90 (212) 334 69 70

E-mail

teknik@hifas.com

Visual Equipment & Presentation Systems Rental - II

Hall No.

Booth No.

Exhibitor Phone No
 Address GSM No
 City / Country Fax No
 Authorized Person E-mail

LCD TV

Cinsi	Sipariş / Ad	Birim Fiyat	Toplam - €
20" LCD TV		€ 290	
26" LCD TV		€ 380	
32" LCD TV		€ 600	

CAMERA EQUIPMENT AND RECORDING SERVICE

Product	Order Qty.	Unit Price	€ Total
Betacam Camera (Including camera operator)		€ 850	
VHS Camera (Including camera operator)		€ 325	

OFFICE EQUIPMENT

Product	Order Qty.	Unit Price	€ Total
Desktop Computer (P4, 256 MB, 40 GB HD DVD R)		€ 150	
Note Book (P4, 256 MB, 40 GB HD DVD R)		€ 300	
Laser Printer		€ 180	
LCD Monitor 15"		€ 160	
LCD Monitor 17"		€ 190	
LCD Monitor 19 or 20"		€ 380	
Fax Machine / Termal		€ 150	
Fax Machine / A4		€ 195	
Photocopier Machine		€ 980	
Remote Kontrol Full Function Laser Pointer		€ 120	

GENERAL TOTAL

€

- Fees for extra booth equipment or services ordered, for CeBIT Bilişim Eurasia have to be paid during the fair in cash.
- VAT is not included in the prices
- The above mentioned prices are valid for requests send to HIF A.Ş. until 14th August, 2007.
- Any orders that reach HIF A.Ş. after 14th August, 2007 and orders given at the Fair shall be charged for at arate 50 % higher than the indicated price.
- Our stocks are limited.



.....

Date

Stamp / Authorized Signature